

1958
Engineering Data and Ratings



UNITED ELECTRONICS

CLIPPER DIODE • RECTIFIER TUBES

HIGH VACUUM... HIGH VOLTAGE INTERNAL ANODE TYPES

All of the half-wave rectifier and clipper diodes described herein employ anodes of specially processed electronic graphite. For over 22 years UNITED ELECTRONICS COMPANY has led the Industry in the design and production of graphite anode tubes which are specially meritorious in handling maximum heat dissipation in convection cooled internal anode design. Since graphite approaches the characteristics of a black body its heat radiating capability is far superior to that of any metal employed as anode material in tubes. A graphite anode will dissipate more than three times the heat of a comparably sized metal anode. The high thermal conductivity of graphite permits uniform heat distribution . . . avoiding "hot spots" and permitting anode operating temperatures up to 820°C. Since the material is infusible no anode warping or puncture can occur.

BULLETIN CDB-3

UNITED ELECTRONICS COMPANY

42 SPRING STREET, NEWARK 4, NEW JERSEY

Since 1934

ELECTRICAL AND PHYSICAL DATA

TYPE	CATHODE	RECTIFIER RATINGS					CLIPPER DIODE RATINGS					NET WEIGHT OUNCES	SHOCK RATING	MOUNTING POSITION
		FILAMENT		epx kv	ib a	Ib mAdc	FILAMENT		epx kv	ib a	Ibrms mAac			
		Vac	Aac				Vac	Aac						
3B24WA	Bonded Thoria Filament	5.0	3.0	20	.300	60						2¼	450G	ANY
	(½ Filament)	2.5	3.0	20	.150	30								
3B29	Unipotential Oxide	2.5	4.9	16	.250	65	2.5	4.9	10	8	240	2½	—	ANY
217C	Thoriated Tungsten	10.0	3.25	7.5	.600	150						7	—	VERTICAL
371B	Thoriated Tungsten	5.0	10.3	25	1.5	300						5¾	—	VERTICAL
543	Bonded Thoria Filament	5.0	5.0	30	.400	100						2½	375G	ANY
				15	.600	150								
558	Bonded Thoria Filament	5.0	12.0	15	.840	300	5.0	12.0	15	7	470	3	300G	ANY
576A	Thoriated Tungsten	5.0	14.0	25	2.5	500	5.4	15.0	25	12	800	5½	—	VERTICAL
577	Thoriated Tungsten	5.0	10.3	25	1.5	300						5	—	VERTICAL
578	Thoriated Tungsten	5.0	6.0	40	.750	100						4	—	VERTICAL
582	Unipotential Oxide	2.5	4.9	7	.800	210						2½	—	ANY
				9	.750	200								
583	Unipotential Oxide	2.5	4.9	17	.250	65	2.5	4.9	15	8	240	2½	375G	ANY
593	Thoriated Tungsten	5.0	10.3	25	1.5	300						5	—	VERTICAL
596*	Filamentary Oxide Coated	5.0	3.0	4.5	.165	55						3½	—	VERTICAL
				2.3	.825	275								
705WA	Bonded Thoria Filament	5.0	5.0	30	.400	100						3¼	300G	ANY
				15	.600	150								

*FULL-WAVE RECTIFIER with Metal Anodes.

BONDED THORIA FILAMENTS:

Extremely rugged, and capable of higher emission than the conventional thoriated tungsten filament, the bonded thoria tungsten core emitters used in types 3B24WA, 543, 558 and 705WA will yield exceptionally long life under the most severe environmental conditions.

INSTALLATION:

Metal bases and all unused pins should be connected externally to one of the filament pins to prevent corona.

AVERAGE PLATE CHARACTERISTICS CURVES

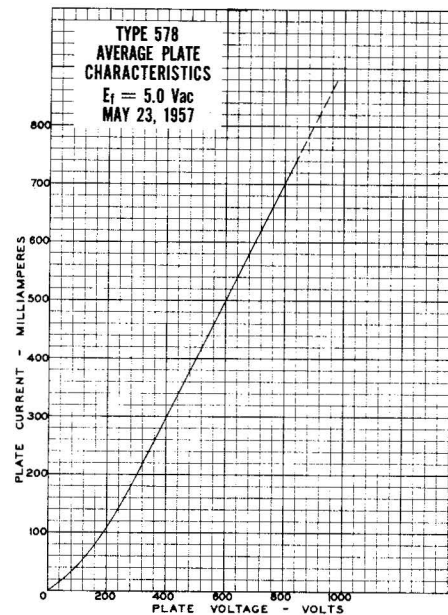
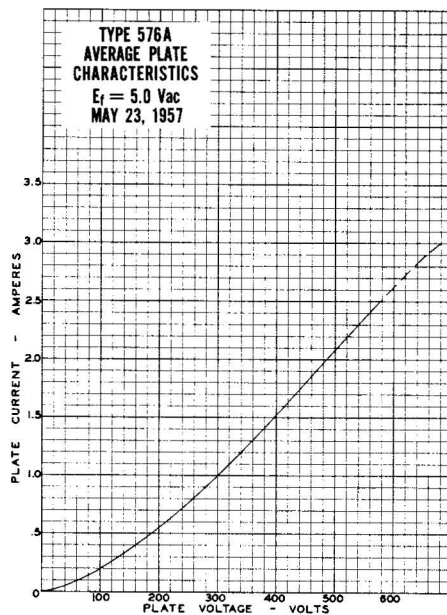
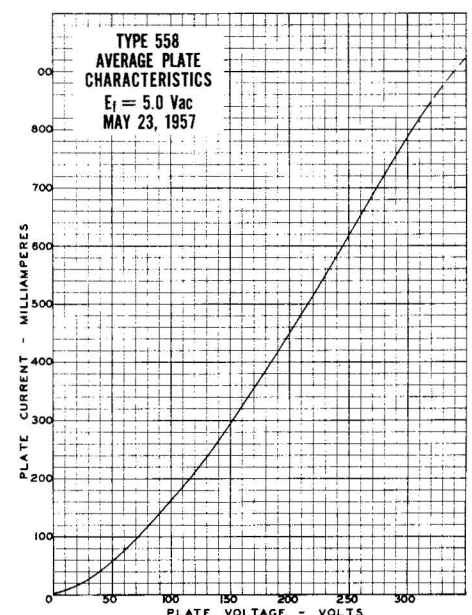
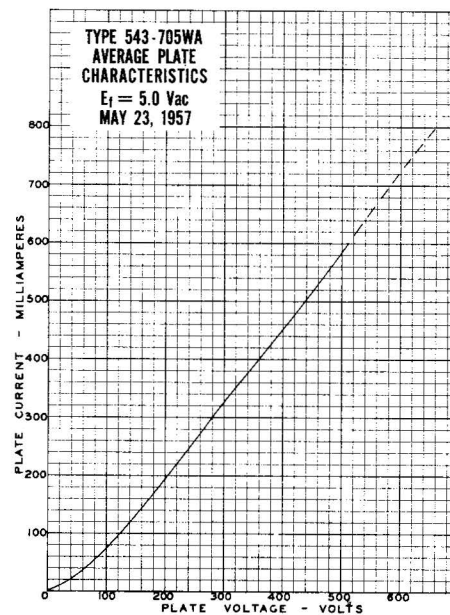
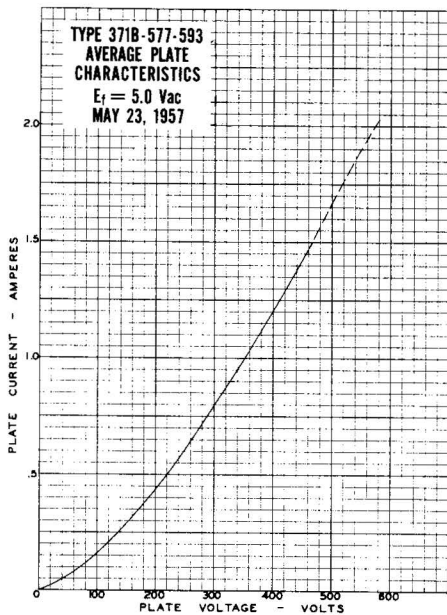
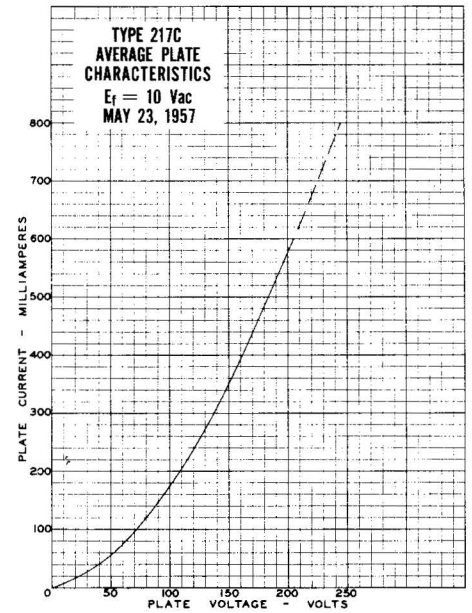
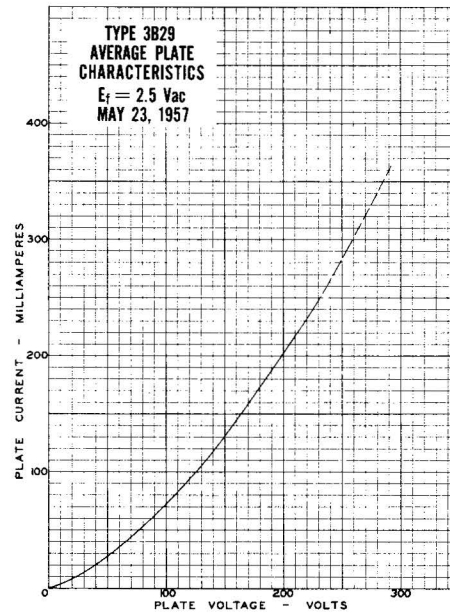
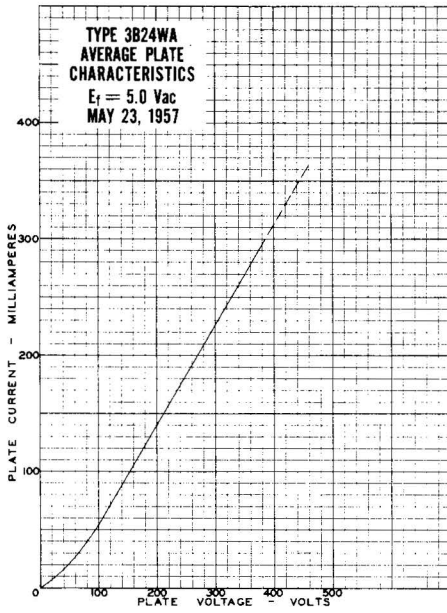

AVERAGE PLATE CHARACTERISTICS CURVES

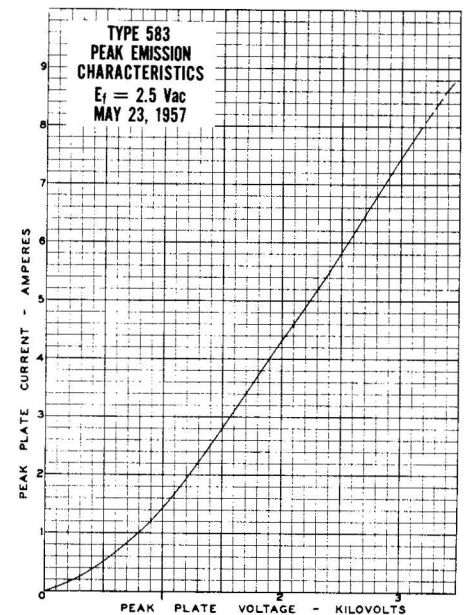
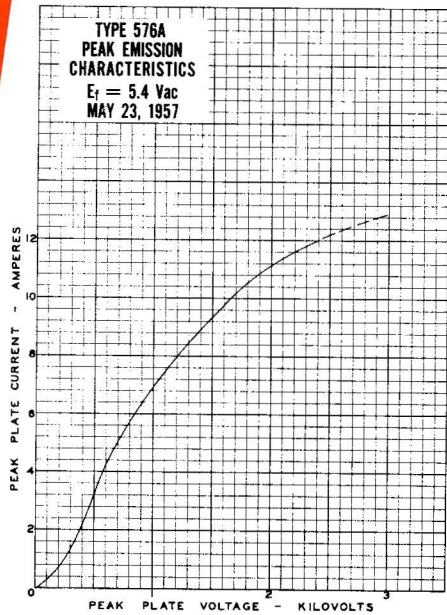
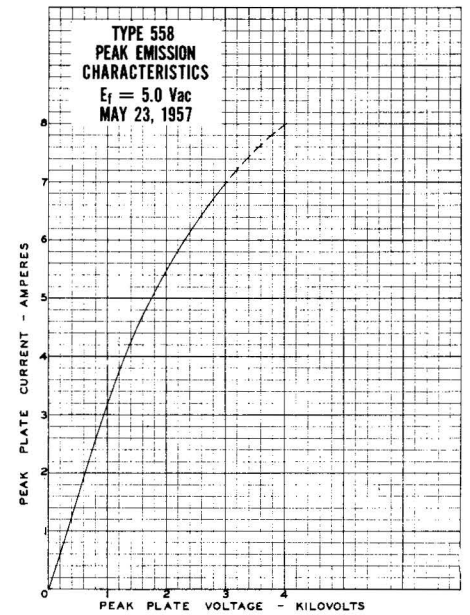
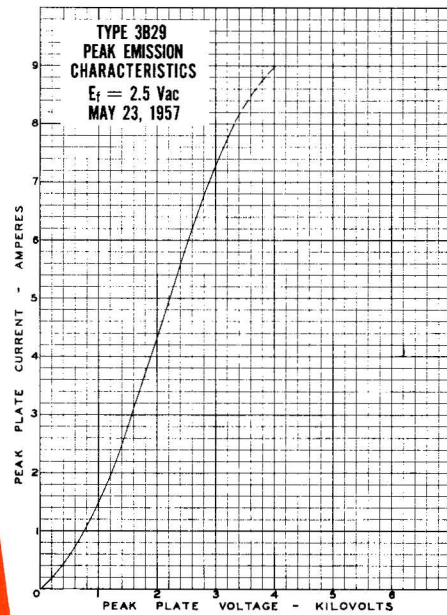
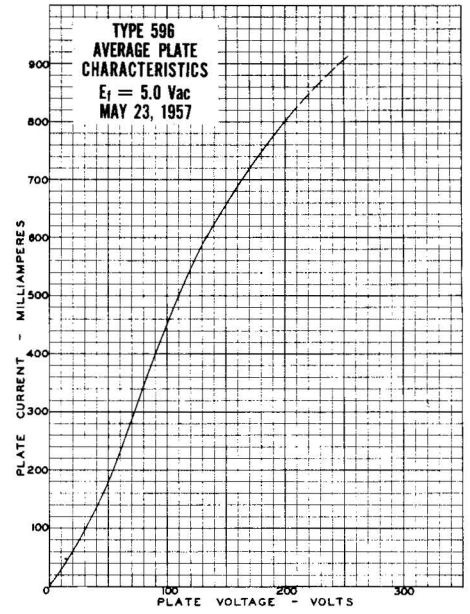
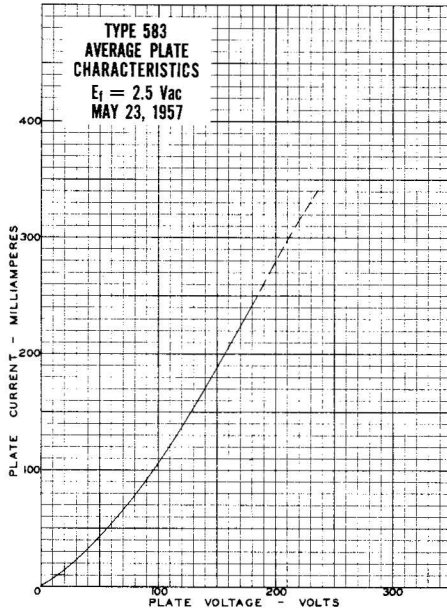
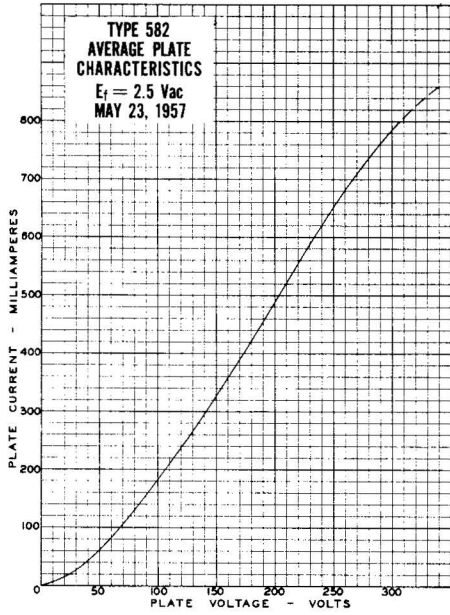

PEAK EMISSION CHARACTERISTICS CURVES



TYPE 3B24WA

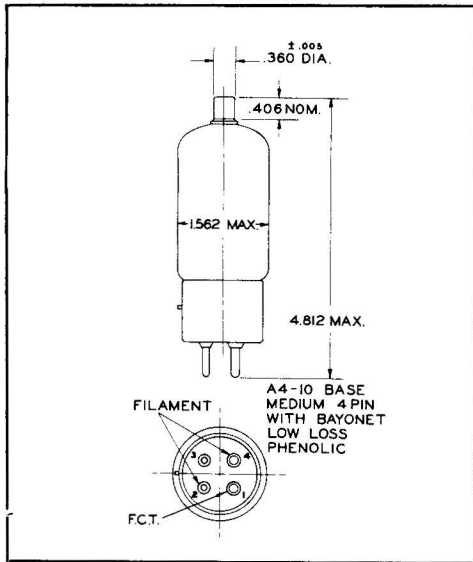

TYPE 3B29

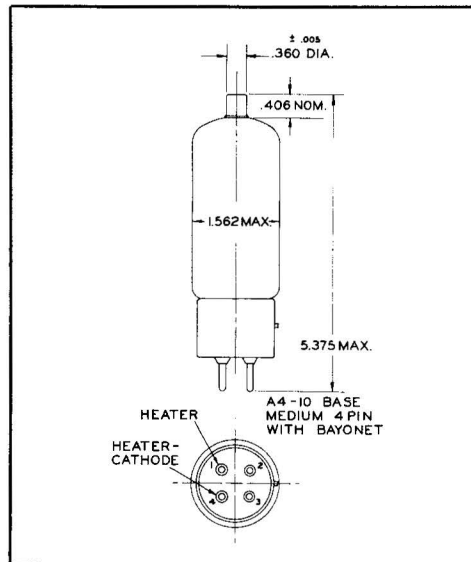

TYPE 217C

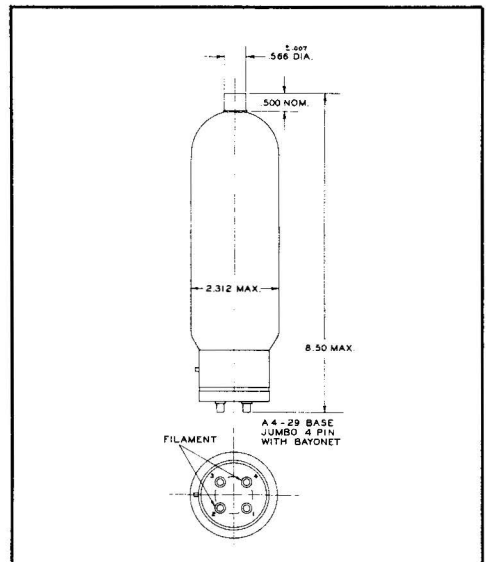

TYPE 371B

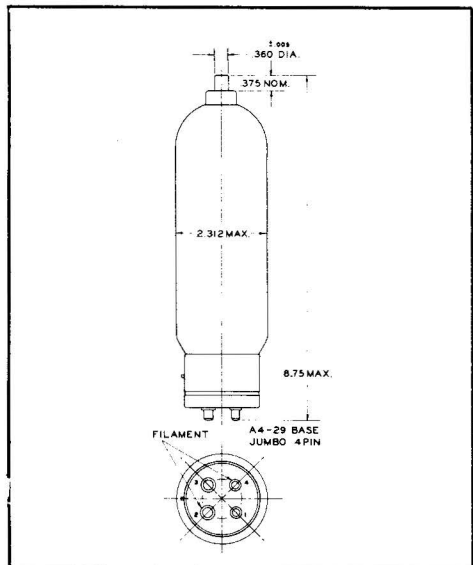

TYPE 543

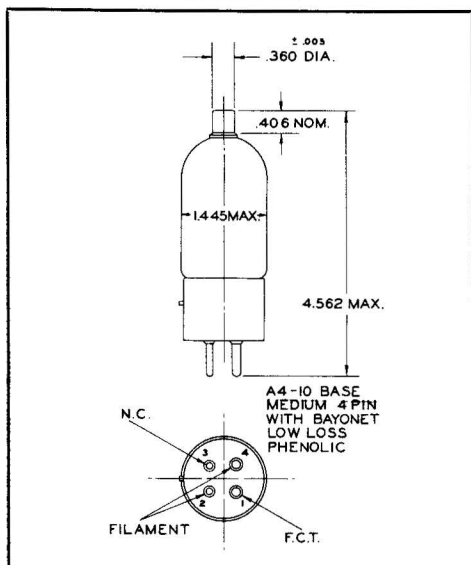

TYPE 558

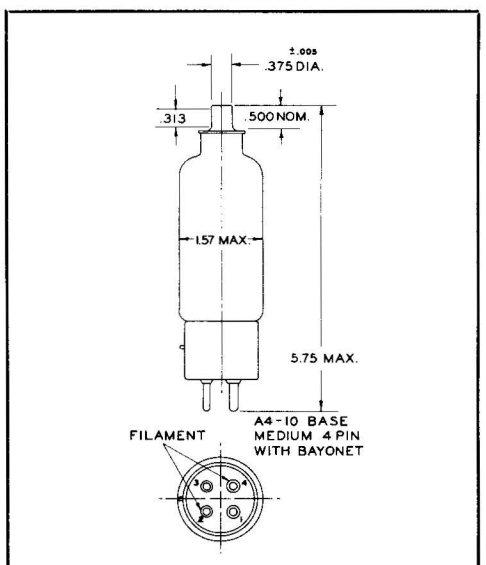

TYPE 576A

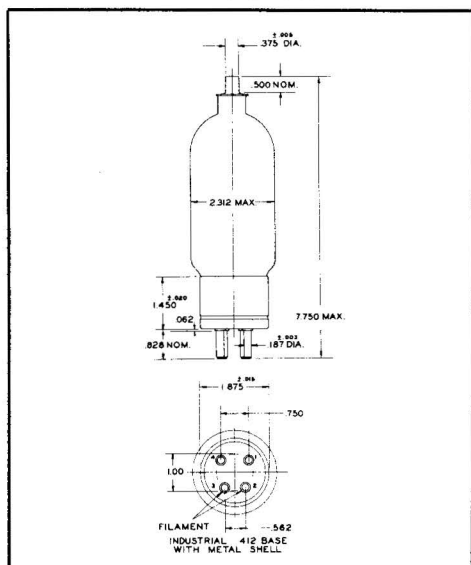

TYPE 577

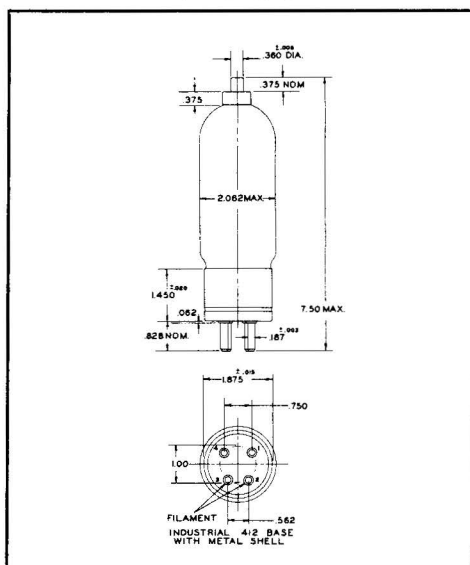



TYPE 578

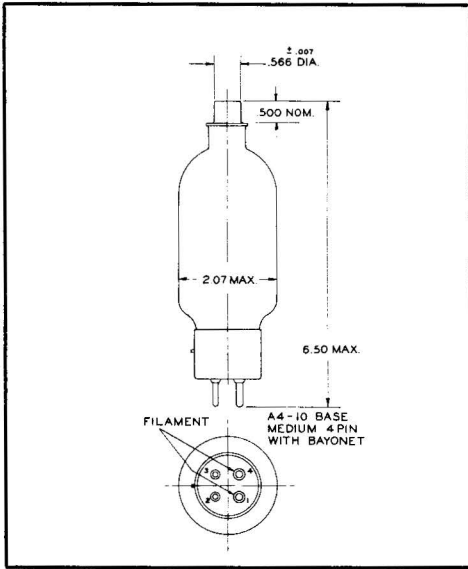

TYPE 582

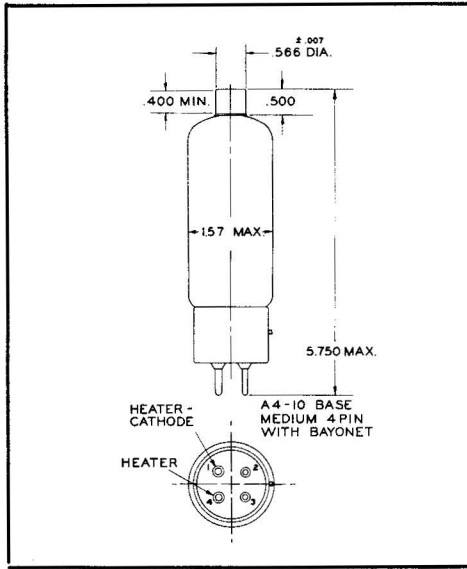

TYPE 583

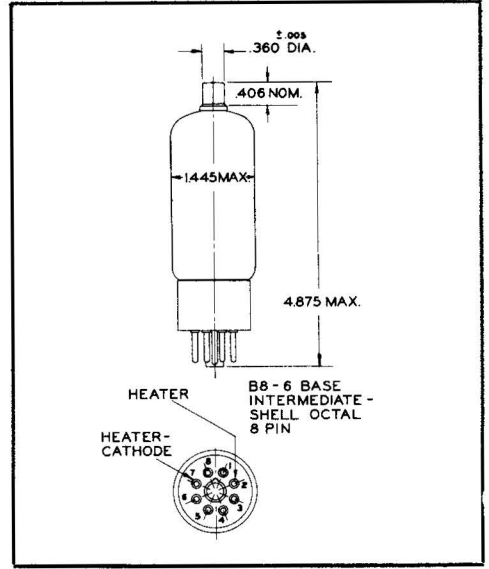

TYPE 593

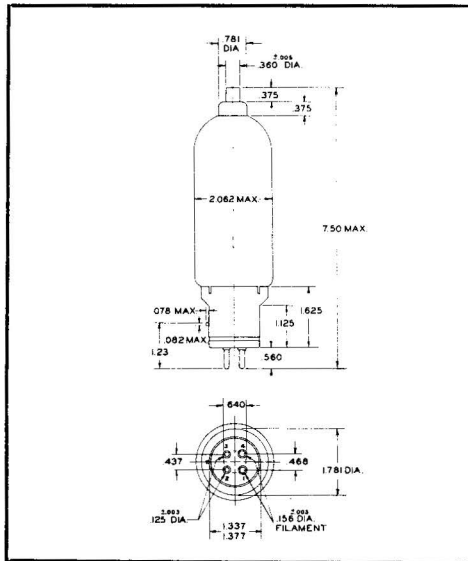

TYPE 596

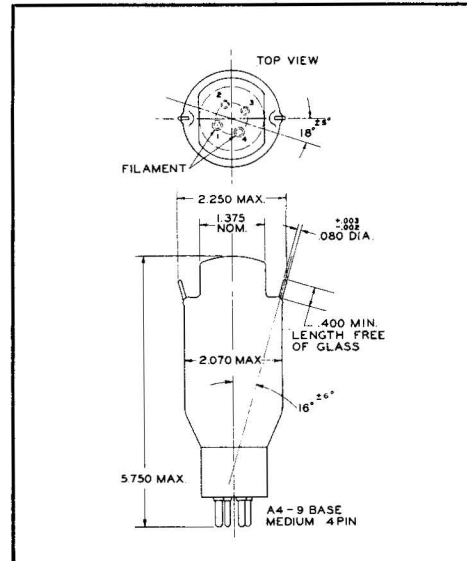

TYPE 705WA

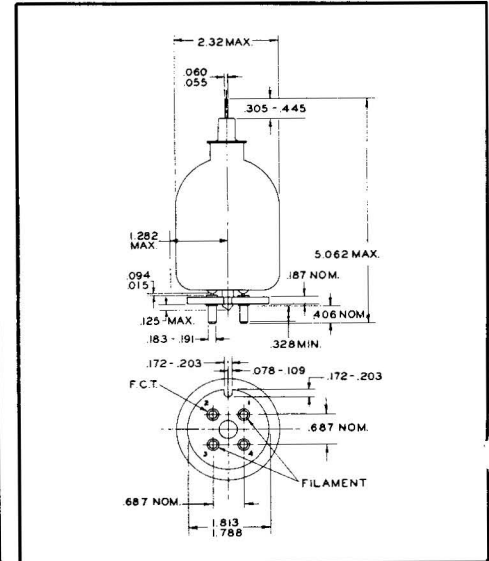

Write for Bulletin: CDB1 — Miniaturized External Anode Diodes
 CDB2 — Major Series, Clipper Diode — Rectifier Tubes
 CDB4 — Vacuum Capacitors — Variable and Fixed Types
 CDB5 — Electron Power Tubes; Transmitting and Industrial Power Tubes